

8HP45

8-Gang-Automatgetriebe für Pkw
8 speed automatic transmission for cars

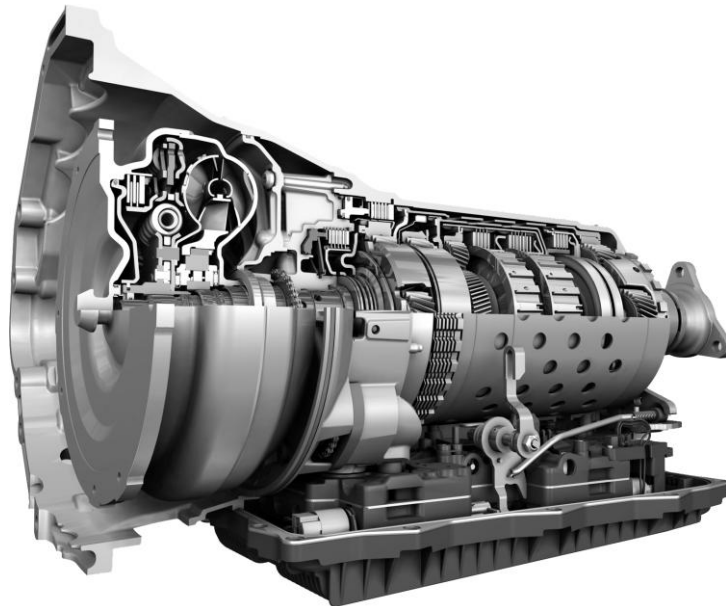

| Getriebetyp / Transmission type | | 8HP45 | |
|--|---|---|---------------------------------|
| Antriebsart Type of drive | | Standard / Standard drive | |
| Eingangsdrehmoment Input torque | | max. 450 Nm | max. 500 Nm |
| Drehmomentwandler Torque converter | | NW 235 TTD/ZDW/DAT NW240 DAT | NW 240 DAT (Diesel / diesel) |
| Standard-Übersetzungen / Standard ratios Gang / Gear | | | |
| | 1 | 4.714 | |
| | 2 | 3.143 | |
| | 3 | 2.106 | |
| | 4 | 1.667 | |
| | 5 | 1.285 | |
| | 6 | 1.000 | |
| | 7 | 0.839 | |
| | 8 | 0.667 | |
| | R | -3.295 | |
| Getriebespreizung Transmissions spreading | | 7.071 | |
| Masse ohne Anbauteile (incl. Öl) Weight without ancillaries (incl. oil) | | 77 kg | 79 kg |
| Ölmenge Oil capacity | | ≈ 9 dm ³ | |
| Getriebeöl Transmission oil | | Lebensdauerölfüllung Lifetime oil fill | |

8HP45

Einbaumaße / Installation dimensions

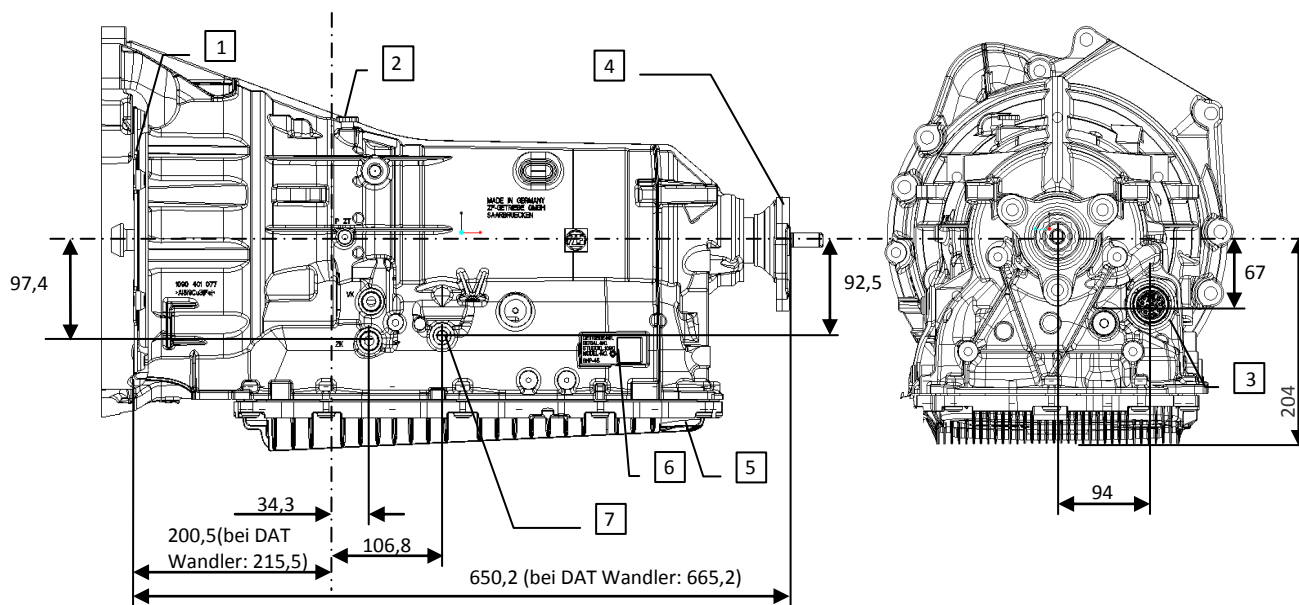

- | | | | |
|---|---|---|---|
| 1 | Wandler / Torque converter | 5 | Ölablass / Oil drain |
| 2 | Entlüfter / Breather | 6 | Öleinfüllung und Ölüberlaufmessung / Oil fill and oil overflow |
| 3 | Steckeranschluss zum Fahrzeugsystem / Plug connection to vehicle systems | 7 | Notentriegelung Parksperr (Shift-by-wire) oder Wählhebel (manuell) Emergency disengagement of parking brake (Shift-by-wire) or selector lever (manually) |
| 4 | Abtrieb / Output | | |

Highlights

- **Hohe Gesamtspreizung bei kleineren Gangsprüngen / High total spreading with small gear steps**
- **Niedere Schleppmomente / low drag torque**
- **Hochwirksame Torsionsschwingungsdämpfer / highly effective torsionsvibration absorber**
- **Standkopplung / Neutral idle control**
- **Mechatronik / Mechatronic**
- **ASIS – adaptive Schaltstrategie / ASIS – adaptive shifting strategy**
- **Hohe Leistung bei geringem Gewicht, Innovatives Radsatzkonzept / High power-to-weight ratio, innovative gear set concept**
- **Allradfähig / AWD capable**